

FAST ACTIVE NOISE CONTROL FOR ROBUST SPEECH ACQUISITION

Luis Vicente⁽¹⁾, *Stephen J. Elliott*⁽²⁾ and *Enrique Masgrau*⁽¹⁾

⁽¹⁾ Dept. of Electron. Eng. and Commun., University of Zaragoza, E50015 Zaragoza, SPAIN

⁽²⁾ ISVR, University of Southampton, Southampton SO17 1BJ, UNITED KINGDOM

E-mail: lvicente@posta.unizar.es, sje@isvr.soton.ac.uk, masgrau@posta.unizar.es

Abstract: Active noise control (ANC) can be a valuable resort for robust speech acquisition. Furthermore, this technique can have the added benefit of minimising the Lombard effect. In the context of broadband active noise cancellation, the adaptive algorithm most widely used is the well-known Filtered-x Least Mean Squares (FxLMS). In the present work we study an alternative to FxLMS algorithm that tries to overcome its sometimes slow convergence without loss of cancellation capability. The alternative presented here is the ALE + FxLMS system, where an Adaptive Line Enhancer (ALE) is used as decorrelating stage for the FxLMS algorithm. The single-channel case (one reference signal, one actuator and one error sensor) and three different extensions of the system to the multiple channel case are presented and evaluated. The proposed system has proven to be able to achieve faster convergence with reference to the single FxLMS, without decorrelating pre-processing.

I. INTRODUCTION

A major problem for speech-based applications when working in noisy environments is the contaminating background noise, which is present together with the speech signals. Active noise control (ANC) techniques try to achieve noise cancellation in the acoustic field by introducing a cancelling “antinoise” wave through an appropriate array of secondary sources. When the “zone of quiet” is generated not only close to the acoustic sensor but also around the speaker this technique can have the added benefit of minimising the Lombard effect.

The generation of the destructively interfering wave is a signal processing task. Generally, ANC systems are adaptive and the adaptation algorithm most widely used in this context is the Filtered-x Least Mean Squares (FxLMS) [1]. In the feedforward control strategy for ANC systems, a reference signal is used to provide advanced information about the primary noise to be cancelled. The spectrum of the reference signal and the one to be cancelled (that is, the primary noise) are not always very similar in the context of broadband active noise cancellation. In that case, it is preferable to have a

white reference, since then no frequency components are weighted more than the others and also, a white reference signal is expected to speed up the convergence of the FxLMS algorithm.

In the present work we introduce the ALE + FxLMS system, where an Adaptive Line Enhancer (ALE) is used as decorrelating pre-processing stage for the FxLMS algorithm. The ALE + FxLMS system aims to improve the convergence of the whole adaptive system at the expense of increased computational complexity. The single-channel case as well as the extension of the system to the multiple-channel case, where strongly correlated reference signals can be found, are studied. Three different multiple-channel generalisations are presented. The performance of these systems is evaluated, with reference to a single FxLMS, without pre-processing.

II. ALE + FXLMS SYSTEM

The main drawback of the FxLMS algorithm is its relatively slow and signal-dependent convergence, which is determined by the eigenvalue spread of the underlying correlation matrix of the input signal. The fastest convergence is obtained when the correlation matrix is diagonal since convergence modes are not coupled. In this case the whole adaptive filter of order L can be seen as L adaptive filters of just one coefficient converging independently. Therefore, by properly choosing the adaptation step sizes of these independent systems, it is possible to make every mode converge at the same speed, what is equivalent to minimising the eigenvalue spread.

The correlation matrix can be made diagonal by whitening the input signal, that is to say, by orthogonalising it in time. The Adaptive Line Enhancer (ALE) is a well-known adaptive structure [2], [3] which is able to whiten the signal when the decorrelation delay is just one sample, $\Delta=1$ (Fig. 1). This decorrelation delay will be assumed from now on. The approach of the ALE + FxLMS system consists in conditioning the FxLMS reference signal by pre-processing it with an ALE system to obtain a decorrelated or white version of it,

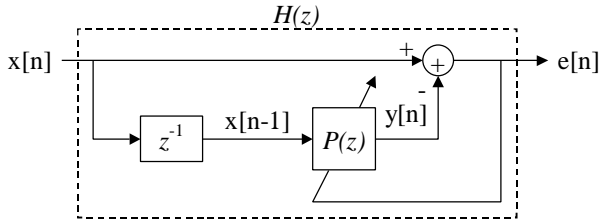

FIGURE 1. Adaptive Line Enhancer (ALE) with decorrelation delay $\Delta = 1$.

which is expected to speed up the converge of the whole system.

Due to the unavoidable presence of the secondary transfer function $S(z)$, the FxLMS adaptation process does not use the input or reference signal but the “filtered-x” signal, which is generated by filtering with a model of the secondary transfer function (Fig. 2.a). For that reason, it is this filtered-x signal the one that determines the convergence properties of the system, although the input to the adaptive filter is the reference signal itself. Therefore, to minimise eigenvalue spread it is the filtered-x signal the one that should be white.

The first ALE + FxLMS system we studied (Fig2.b) whitens the reference signal, keeping the ALE and FxLMS systems independent. The whitened filtered signal, $x_D'[n]$, is the one that should be white to speed up convergence but the secondary filtering process might colour again the whitened signal, $x_D[n]$. So, this system could speed up convergence, but it could also slow it down, depending on the “colouring” ability of the secondary transfer function.

The actual ALE + FxLMS system that we study in this work (Fig. 2.c) orthogonalises the filtered-x signal, so the ALE system is embedded in the FxLMS system. In this case, the input to the adaptive filter, $W(z)$, is the reference signal filtered by $H(z)$, which is a copy of the ALE system. This system ability to speed up convergence is independent of the secondary transfer function.

The ALE system is a prediction error filter (whose transfer function would be $H(z) = 1 - z^{-1} P(z)$) with $Q+1$ coefficients, being Q the number of coefficients of $P(z)$. The filter $P(z)$ is a prediction filter, since the “desired” signal at the output of it is an anticipated version of the input signal. The output signal of the ALE system is the prediction error, that is the whitened version of the input signal. The adaptive algorithm used in this work for the ALE system was the Least Mean Squares (LMS) [4].

The whitening capability of the ALE system will depend on the input signal statistics, as well as on the prediction filter order, Q . In general, the optimum whitening filter solution will be an IIR filter. For that reason, the greater the order of the FIR filter $P(z)$, the better approximation to the optimum, but also the slower convergence of the ALE system.

Due to the adaptive nature of the ALE system, there will always be a misadjustment error or noise added to the desired whitened signal. The power of this noise will

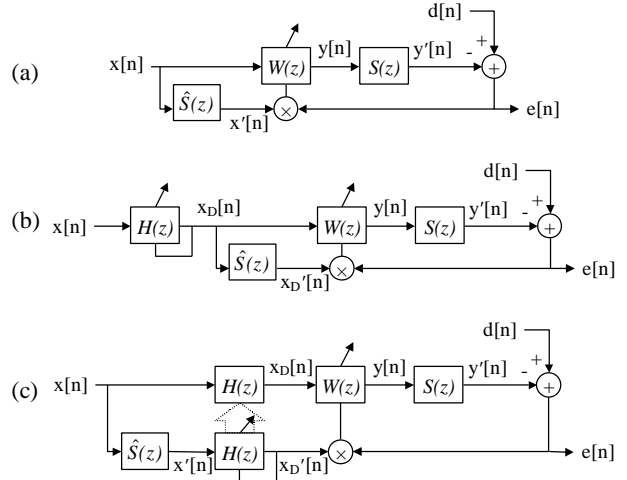

FIGURE 2. Block diagrams: (a) FxLMS, (b) Pre-processing ALE + FxLMS and (c) Embedded ALE + FxLMS.

be directly proportional to the power of the whitened signal, being the signal to noise ratio at the output of the ALE equal to the inverse of the misadjustment factor. This factor is proportional to the adaptation step size. The effects of this noise are generally masked by the components in the primary noise that cannot be cancelled. However, there will be an upper limit in the adaptation step size for the ALE algorithm to ensure that the cancellation capability of the global system is not affected by the misadjustment noise at the output of the ALE.

Considering that the speed of convergence depends basically on the input signal to the adaptive filter, and not on the desired signal output, the ALE stage will have to face the same convergence problems that we want to eliminate from the FxLMS. However, experimental results show that convergence of the ALE + FxLMS system is faster than the single FxLMS. The reason for this is that it is not the convergence speed of the ALE that matters, but the “whitening speed”, since any improvement in its adaptation signal conditioning is seized immediately by the FxLMS.

III. SINGLE-CHANNEL RESULTS

In the next example, performances of ALE + FxLMS and single FxLMS are compared. In both systems the filter $W(z)$ has the same number of coefficients and it is used the same normalised adaptation step size.

The reference signal is a pink noise, obtained by low pass filtering of a white noise. The cancellable component of the primary noise is also obtained by band pass filtering of the same white noise that generates the reference signal. There is delay enough between both signals to make possible the cancellation. The uncancellable component of the primary noise is an

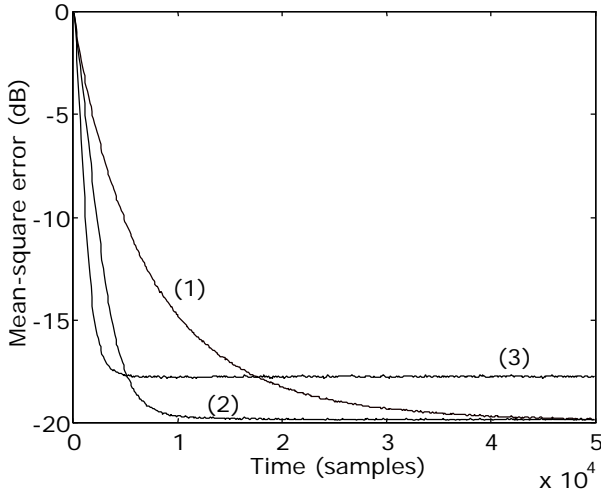

FIGURE 3. Learning curves comparison for single channel systems: (1) FxLMS, (2) ALE + FxLMS, (3) ALE + FxLMS with high ALE adaptation step size.

uncorrelated noise that limits the achievable cancellation to 20 dB.

The learning curves of the two compared systems are shown in Fig. 3. There are two learning curves for the ALE + FxLMS system, corresponding to two different ALE adaptation step sizes. Comparing curves (1) and (2), we can see that there is a significant speed improvement with the ALE + FxLMS system while the cancellation capability is not affected. The third curve corresponds to the ALE + FxLMS system with high ALE adaptation step size. In this case, the convergence is even faster, since the whitening is faster, but the misadjustment noise introduced by the ALE system is not masked by the uncancellable component of the primary noise and the steady-state mean-squared error level is higher.

IV. MULTIPLE-CHANNEL SYSTEM

In this section we study three possible extensions of the single-channel ALE system, to use as decorrelating stages with the multiple-channel FxLMS algorithm (also known as Multiple Error LMS, [1]). The previous discussion about the pre-processing ALE + FxLMS and the embedded ALE + FxLMS systems also holds for the multiple-channel case. So, the multiple-channel ALE stage will also be embedded in the FxLMS system.

In the multiple-channel case there can be a strong cross-correlation between the different input signals. This correlation is not desirable, since it generates coupling of the solutions for the different adaptive filters which slows the adaptation. In the single-channel case, whitening (time decorrelation) the filtered-x signal is enough to speed up convergence. But in the multiple-channel case decorrelation between the different filtered-x signals (inter-signal decorrelation) will also be necessary.

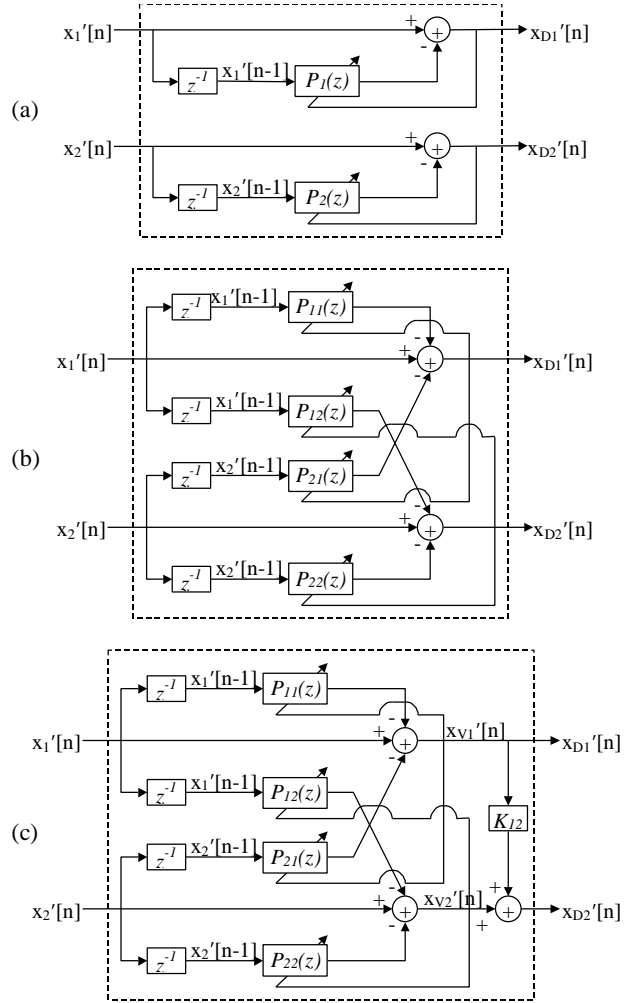

FIGURE 4. Multiple channel ($J=2$) decorrelation systems: (a) Multi-scalar ALE, (b) Vectorial ALE and (c) Vectorial ALE + Cross-correlation in $n=0$ elimination.

The first of this multiple-channel decorrelating systems is the Multi-scalar ALE system (Fig. 4.a). It is not really an extension of the ALE to a multiple-channel case, but a single-channel ALE (or scalar ALE) repeated J times, where J is the number of input signals. In this case, it is not possible to remove the cross-correlation between the different input signals since in every single-channel ALE system just one input signal is filtered. So, the output is whiter than the input, but there will still remain most of the cross-correlation between signals.

In the Vectorial ALE system (Fig. 4.b), some inter-signal decorrelation is possible because all of the J input signals are involved in the computation of every output signal. On the other hand, the computational cost of this system is much bigger, with a quadratic increase with the number of input signals (J^2 adaptive filters in the Vectorial ALE and just J in the Multi-scalar ALE). This system is the vectorial extension of the single-channel ALE system, where the input to the system is a vector of data samples, instead of just one data sample, that is used

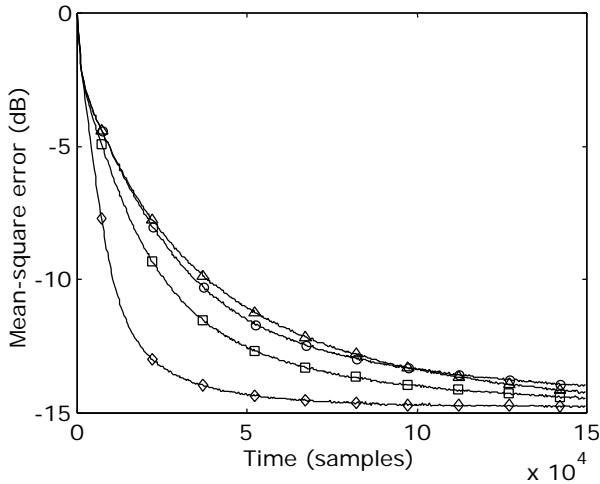

FIGURE 5. Learning curves comparison for multiple channel systems: FxLMS (○ - line), Multi-scalar ALE + FxLMS (△ - line), Vectorial ALE + FxLMS (□ - line) and Vectorial ALE + Cross-correlation in $n=0$ elimination + FxLMS (◇ - line).

to compute J different output signals. However, the cross-correlation in the same time sample,

$$R_{x_{D1}x_{D2}}(0) = E\{x_{D1}[n]x_{D2}[n]\}$$

cannot be eliminated with this system.

The last system (Fig. 4.c) takes the whitened outputs of the Vectorial ALE, $x_{vj}[n]$, and eliminates the cross-correlation in $n=0$. The next algorithm was used in the present work to iteratively calculate the final outputs, $x_{Dj}[n]$ ($j=1, \dots, J$):

$$x_{Dj}[n] = x_{vj}[n] - \sum_{i=1}^{j-1} x_{Di}[n] \frac{R_{x_{Di}x_{vj}}(0)}{R_{x_{Di}x_{Di}}(0)} = x_{vj}[n] - \sum_{i=1}^{j-1} x_{Di}[n] K_{ij}$$

The cross-correlation terms in the previous formula were estimated adaptively.

Multiple-channel ALE + FxLMS performance using the previous multiple-channel ALE extensions will depend on the cross-correlation levels between the different filtered-x signals of the multiple-channel FxLMS. When the cross-correlation level is low, the Multi-scalar ALE should be enough to speed up convergence while not increasing computational cost very much. But with high cross-correlation levels, the Multi-scalar ALE will do nothing and at least Vectorial ALE will be needed.

In the example of Fig. 5 the learning curves for a high cross-correlation level case of a $2 \times 1 \times 1$ system (2 references, 1 actuator, 1 sensor) are shown. It can be seen that the Multi-scalar ALE + FxLMS system does not improve performance at all, whereas the Vectorial ALE systems are clearly faster than the single FxLMS system. Since the cross-correlation in $n=0$ (Fig. 6) is high, there is also a big improvement in the convergence speed when the Vectorial ALE is used together with the cross-correlation in $n=0$ elimination, which is the only multiple-channel system that completely diagonalises the correlation matrix.

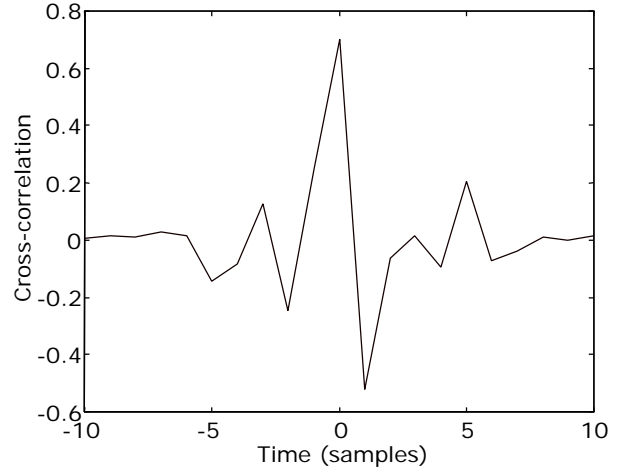

FIGURE 6. Cross-correlation function of the filtered-x signals in the FxLMS system for the multiple-channel example.

V. CONCLUSIONS

In the present work we have introduced a new algorithm, the ALE + FxLMS, for broadband active noise control. The single-channel and three different multiple-channel systems have been studied and evaluated. The single-channel algorithm and the multiple-channel algorithm with Vectorial ALE and cross-correlation in $n=0$ elimination have proven to achieve faster convergence than the single FxLMS, at the expense of additional computational complexity: the ALE system and the reference filtering. There is a minimum adaptation step size for the ALE system, so that the misadjustment noise at the ALE output does not limit the cancellation capability of the global system.

ACKNOWLEDGEMENTS

This work was supported by CONSI+D/DGA (grants B226/96 and P64/96) and CAI.

REFERENCES

1. Elliott, S. J., Nelson, P. A., "Active Noise Control", *IEEE Signal Processing Magazine*, **10(4)**, pp. 12-35 (1993).
2. Widrow, B. et al, "Adaptive Noise Cancelling: Principles and Applications", *Proc. of the IEEE*, **63(12)**, pp. 1692-1716 (1975).
3. Zeidler, J. R., "Performance Analysis of LMS Adaptive Prediction Filters", *Proc. of the IEEE*, **78(12)**, pp.1781-1806 (1990).
4. Widrow, B., Stearns S. D., *Adaptive Signal Processing*, New Jersey: Prentice-Hall, 1985, ch. 6.